

Mosaic™ 10 AX switches

Cat. No(s): 0 770 00/01/02/10/11/12/14/21
0 787 10/11/12 - 0 791 01/11/12 - 0 792 01/02/11/12/21

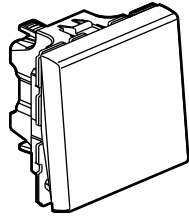

0 770 10/11 - 0 792 11

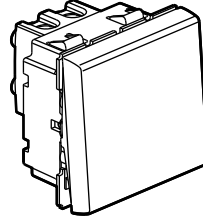

0 770 21 - 0 792 21

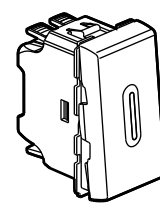

0 770 02 - 0 792 02

1. USE

General lighting control mechanisms with or without signalling components (indicator light).
The mechanisms can be flush-mounted or surface-mounted.
To be equipped with plate.

Antimicrobial products*:







Products are made of silver-ion based antimicrobial* material.

This technology eliminates bacteria, fungi and viruses without creating any immunisation or resistance effects (physical, rather than chemical, destruction).

Particularly suitable for healthcare establishments (hospitals, clinics, nursing homes, laboratories, waiting rooms, etc.) and more generally for areas subject to hygiene restrictions (industrial, shared and restaurant kitchens, waste, etc.).

These products offer an additional way of ensuring the non-proliferation of bacteria, fungi and viruses without interfering with cleaning protocols.

2. RANGE

	Description	Antimicrobial* White	White	Anthracite	Aluminium
	Switch - 1 module	-	0 770 00 ⁽¹⁾	-	-
	Two-way switch - 1 module	0 787 10*	0 770 01	0 791 01	0 792 01
	Two-way switch with LED indicator Equipped with a terminal for neutral connection To be equipped with an indicator - 1 module	-	0 770 02	-	0 792 02
	Switch - 2 modules	-	0 770 10 ⁽¹⁾	-	-
	Two-way switch - 2 modules	0 787 11*	0 770 11	0 791 11	0 792 11
	Two-way switch with LED indicator Equipped with a terminal for neutral connection To be equipped with an indicator - 2 modules	0 787 12*	0 770 12	0 791 12	0 792 12
	Two-way switch with a pull-cord Equipped with cord 1.5m 2 modules	-	0 770 14	-	-
	Intermediate switch - 2 modules	-	0 770 21	-	0 792 21

⁽¹⁾Only 2 automatic terminals.

3. DIMENSIONS (mm)

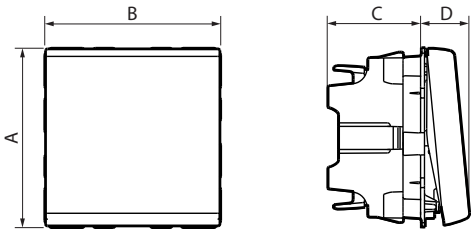

Cat. Nos	A	B	C	D
0 770 00/01/02 - 0 787 10 0 791 01 - 0 792 01/02	45	22,5	24	12.3
0 770 10/11/12 - 0 787 11/12 0 791 11/12 - 0 792 11/12	45	45	24	12.3
0 770 21 0 792 21	45	45	29.7	12
0 770 14	45	45	28.4	22

4. CONNECTION

Cat. Nos	Terminals	Capacity	Stripping	Screwdriver
0 770 21 0 792 21	With screws	2 x 2.5 mm ²	10 mm	Philips n° 1 Posidrive n° 1 Flat-blade 4 mm
0 770 00/01/02 0 770 10/11/12 0 787 10/11/12 0 791 01/11/12 0 792 01/02 0 792 11/12	automatic	2 x 2.5 mm ²	12 mm	-
0 770 14	automatic	2 x 2.5 mm ²	12 mm	-

5. WIRING

Cat. Nos: 0 770 02/12 - 0 787 12 - 0 792 02/12

Illuminated function: Illuminates the switch in the dark.

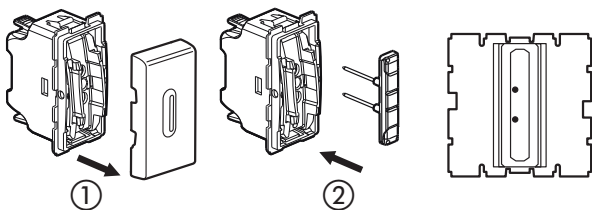

- 1 - Unclip the rocker
- 2 - Insert the indicator light Cat. No. 0 676 86 or Cat. No. 0 676 87

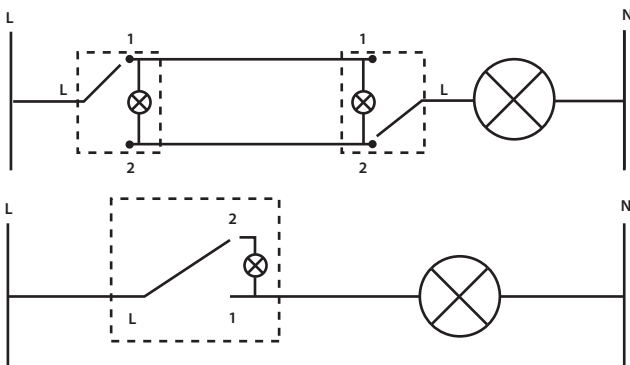

5. WIRING (continued)

Indicator function: The lamp is switched on when the lighting is on.

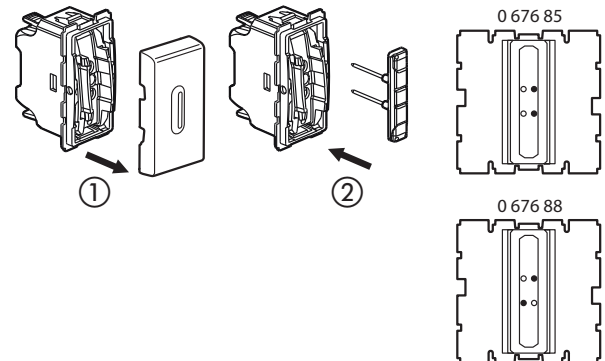

- 1 - Unclip the rocker
- 2 - Insert the indicator light Cat. No. 0 676 88 or 0 676 85

Switch

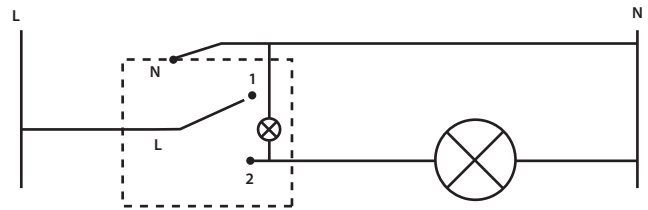

Two-way switch existing cabling, indicator light 0 676 85

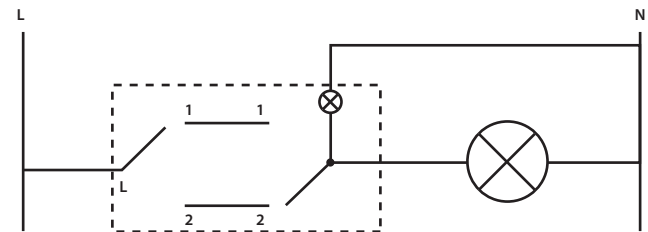

Two-way switch, indicator light 0 676 88

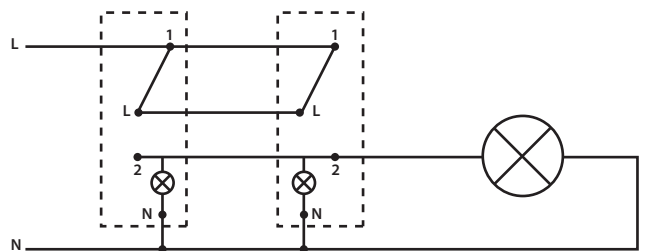

Note: Do not mix old motor (manufacture before July 2014) with new motor (manufacture after July 2014).

6. TECHNICAL CHARACTERISTICS

■ 6.1 Mechanical characteristics

Impact tests: IK 04

Protection against solid bodies and liquids: IP 31 D

■ 6.2 Material characteristics

Rocker: ABS

Base: PC

Rocker support: PC

Halogen-free

UV-resistant

Self-extinguishing:

850°C/30 s for insulating components holding in place live parts.

650°C/30 s for the other insulating components.

■ 6.3 Electrical characteristics

Voltage: 250 VAC

Current: 10 AX expect Cat. No. 0 770 14: 6 AX

■ 6.4 Climate characteristics

Storage temperature: - 10°C to + 70°C

Usage temperature : - 5°C to + 35°C

7. CLEANING

Surface cleaning with a cloth.

Do not use: acetone, tar remover, trichloroethylene.

■ 7.1 Resistance to cleaning products

Resistance to the following agents: Hexane (EN 60669-1), methylated spirits, soapy water, diluted ammonia, pure bleach diluted to 10%, window-cleaning products, pre-impregnated wipes.

■ 7.2 Resistance to hospital-grade cleaning products

Resistance to the following agents: Anios, Surfanios, Bactily sine, Diluted hydrogen peroxide (35%).

Caution: Always test before using other special cleaning products.

8. ACCESSORIES

Lights for switches with indicator light:

Switches	Illuminated	Indicator
0 770 02		
0 770 12		
0 787 12	0 676 86 (230 V / 0.15 mA)	0 676 85 (230 V / 3 mA)
0 792 02	0 676 87 (12/24/48 V)	0 676 88 distributed phase (230 V / 3 mA)
0 792 12		

9. STANDARDS AND APPROVALS

Compliant with installation and manufacturing standards.

See e.catalogue.

*Contains silver ions that limit the development of bacteria on the surface.